



**HIGHLEAD**

**GG80018**

**High-Speed,1-Needle,Lockstitch, Zigzag Stitching Machine**

**Instruction Manual**  
**Parts Catalog**

# A. ARM BED AND ITS ACCESSORIES

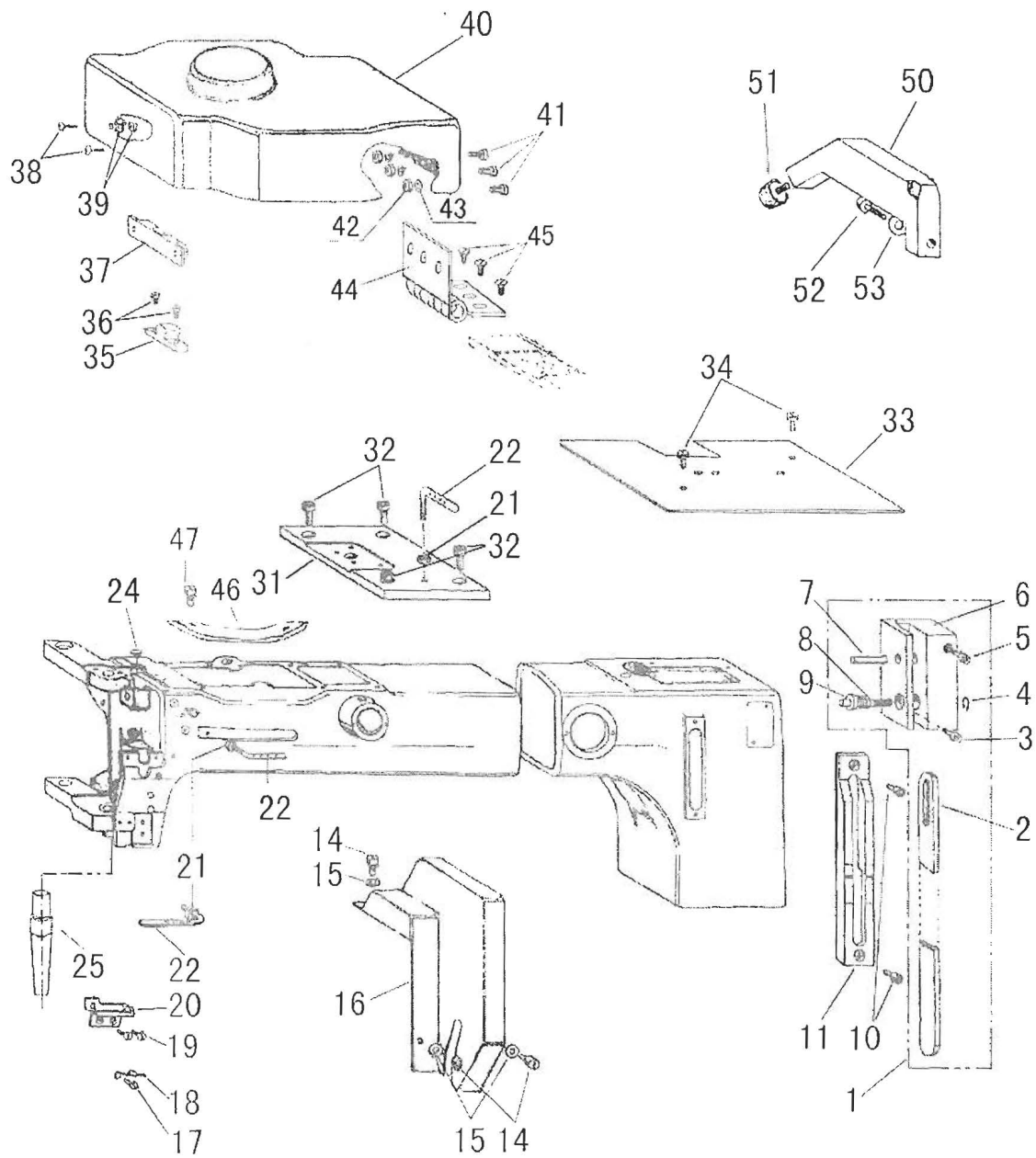

## A. ARM BED AND ITS ACCESSORIES

Fig. No.	Part No.	Description	Pcs.	Remarks
A01	HM811B7101	Board Complete	1	
A02	HM812B8001	Board	1	
A03	H415080120	Screw	1	
A04	H007013080	Retaining Ring	1	
A05	H415080450	Screw	1	
A06	HM813B8001	Block	1	
A07	HM817B8001	Pin	1	
A08	HM031K8001	Spring	1	
A09	HM815B8001	Pin	1	
A10	H401060100	Screw	2	
A11	HM816B8001	Brand	1	
A14	H415040120	Screw	3	
A15	H005001040	Washer	3	
A16	HM819B8001	Guard	1	
A17	HM820B8001	Screw	2	
A18	HM821B8001		1	
A19	HM822B8001	Screw	1	
A20	HM823B8001	Thread guide	1	
A21	H003002060	Nut	1	
A22	HM825B8001	Thread guide	1	
A24	H2000M0090	Oil cup	1	
A25	HM827B8001	Bushing	1	
A31	HM833B8001	Cover	1	
A32	H415060120	Screw	4	
A33	HM835B8001	Cover	1	
A34	H415050120	Screw	4	
A35	HM837B8001	Buckle	1	
A36	HZ08030060	Screw	2	
A37	HM838B8001	Buckle	1	
A38	HZ08030080	Screw	2	
A39	H003002030	Nut	2	
A40	HM839B8001	Cam cover	1	
A41	HZ08030080	Screw	3	
A42	H003002030	Nut	3	
A43	H005001030	Washer	3	
A44	HE009B7101	Gemel complete	1	
A45	H403030050	Screw	3	
A46	HM841B8001	Baffle	1	
A47	H7326E8001	Screw	2	
A50	HM843B8001	Staff	1	
A51	HM844B8001	Block	1	
A52	H415080450	Screw	1	
A53	H005008080	Washer	1	

# A. ARM BED AND ITS ACCESSORIES

Fig. No.	Part No.	Description	Pcs.	Remarks
A54	HM846B8001	Cover	1	

# B. NEED BAR AND THREAD TAKE-UP MECHANISM

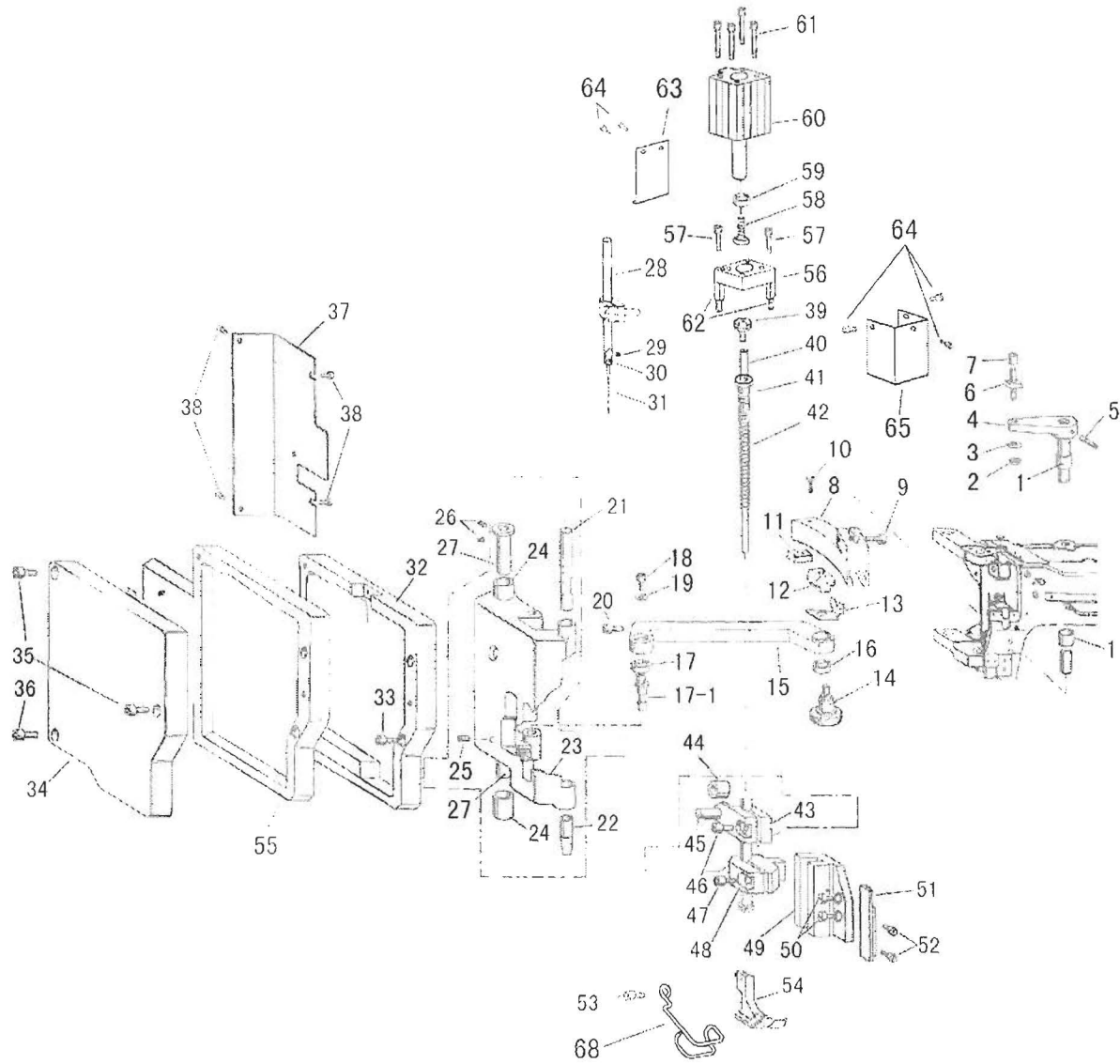

## B. NEED BAR AND THREAD TAKE-UP MECHANISM

Fig. No.	Part No.	Description	Pcs.	Remarks
B01	HM804C8001	Bushing	2	
B02	H003002060	Nut	1	
B03	H005001060	Washer	1	
B04	HM806C7101	Cam shaft complete	1	
B05	H602050260	Pin	1	
B06	HM809C8001	Screw	1	
B07	H7213C8001	Column	1	
B08	HM811C8001	Guide	1	
B09	H415060180	Screw	1	
B10	H415030120	Screw	1	
B11	HM812C8001	Block	1	
B12	HM813C8001	Slide block	1	
B13	HM814C8001	Brand	1	
B14	HM815C8001	Screw	1	
B15	HM817C8001	Link	1	
B16	HM818C8001	Bushing	1	
B17-1	HM820C8001	Shaft	1	
B17	HE00002010	Bearing	1	GE10E
B18	H415060060	Screw	1	
B19	H005001060	Washer	1	
B20	H415040120	Screw	1	
B21	HM823C8001	Bushing	1	
B22	HM824C8001	Bushing	1	
B23	HM825C8001	Needle bar bracket	1	
B24	HM826C8001	Bushing	2	
B25	H415060060	Screw	1	
B26	H415060100	Screw	2	
B27	HM827C8001	Pin	2	
B28	HM828C8001	Needle bar	1	DY3*26
B29	H415040060	Screw	1	
B30	HF206D8001	Thread guide	1	
B31	HM829C8001	Needle	1	
B32	HM830C8001	Block	1	
B33	H415060200	Screw	3	
B34	HM832C8001	Face plate	1	
B35	H415050400	Screw	2	
B36	H415050160	Screw	1	
B37	HM831C8001	Cover	1	
B38	H415040100	Screw	4	
B39	HM834C8001	Joint	1	
B40	HM835C8001	Presser bar	1	
B41	HM836C8001	Screw	1	
B42	HM837C8001	Spring	1	

## B. NEED BAR AND THREAD TAKE-UP MECHANISM

Fig. No.	Part No.	Description	Pcs.	Remarks
B43	HM839C8001	Block	1	
B44	HM840C8001	Column	1	
B45	HM846C8001	Pin	1	
B46	H415060150	Screw	1	
B47	H415060150	Screw	1	
B48	HM842C8001	Block	1	
B49	HM843C8001	Guide	1	
B50	H7312G8001	Screw	2	
B51	HM844C8001	Guide	1	
B52	H401040060	Screw	2	
B53	H415040080	Screw	1	
B54	HM845C7101	Presser foot complete	1	
B55	HM849C8001	Block	1	
B56	HM852C8001	Platform	1	
B57	H415060350	Screw	2	
B58	HM854C8001	Joint	1	
B59	H003001060	Nut	1	
B60	HM855C8001	Cylinder	1	SDA32×40
B61	H415050500	Screw	4	
B62	HM856C8001	Screw	2	





### C. NEEDLE BAR AND TAKE-UP MECHANISM

Fig. No.	Part No.	Description	Pcs.	Remarks
C01	HM805D8001	Crank	1	
C02	H428060100	Screw	1	
C03	H602050320	Pin	1	
C04	HM808D8001	Shaft	1	
C05	H428060060	Screw	1	
C06	HM809D8001	Link	1	
C07	HM810D8001	Link	1	
C08	HM811D8001	Shaft	1	
C09	H424050040	Screw	1	
C10	HM812D8001	Pin	1	
C11	HM813D8001	Screw	1	
C13	HM816D8001	Joint	1	
C14	H415050100	Screw	2	
C15	HM818D8001	Thread take-up lever	1	
C16	HM819D8001	Bushing	1	
C18	HM821D8001	Upper shaft	1	
C19	HM824D8001	Bushing	1	
C20	H428060060	Screw	2	
C22	H3205J0662	Bearing	1	6204ZNR
C23	H007009200	Washer	1	
C24	HM826D8001	Block	1	
C25	H428080100	Screw	2	
C26	HM834D8001	Belt pulley (small)	1	
C27	H415040060	Screw	2	
C28	HM837D8001	Driving wheel	1	
C29	H428060060	Screw	2	
C30	H3206J0066	Bearing	1	6204ZZ (NTN)
C31	HM841D8001	Pulley	1	
C32	HM843D7101	Collor complete	1	
C33	H431060060	Screw	2	
C34	HM846D8001	Collor	1	
C35	H431060080	Screw	2	

# D. CAM MACHANISM

---

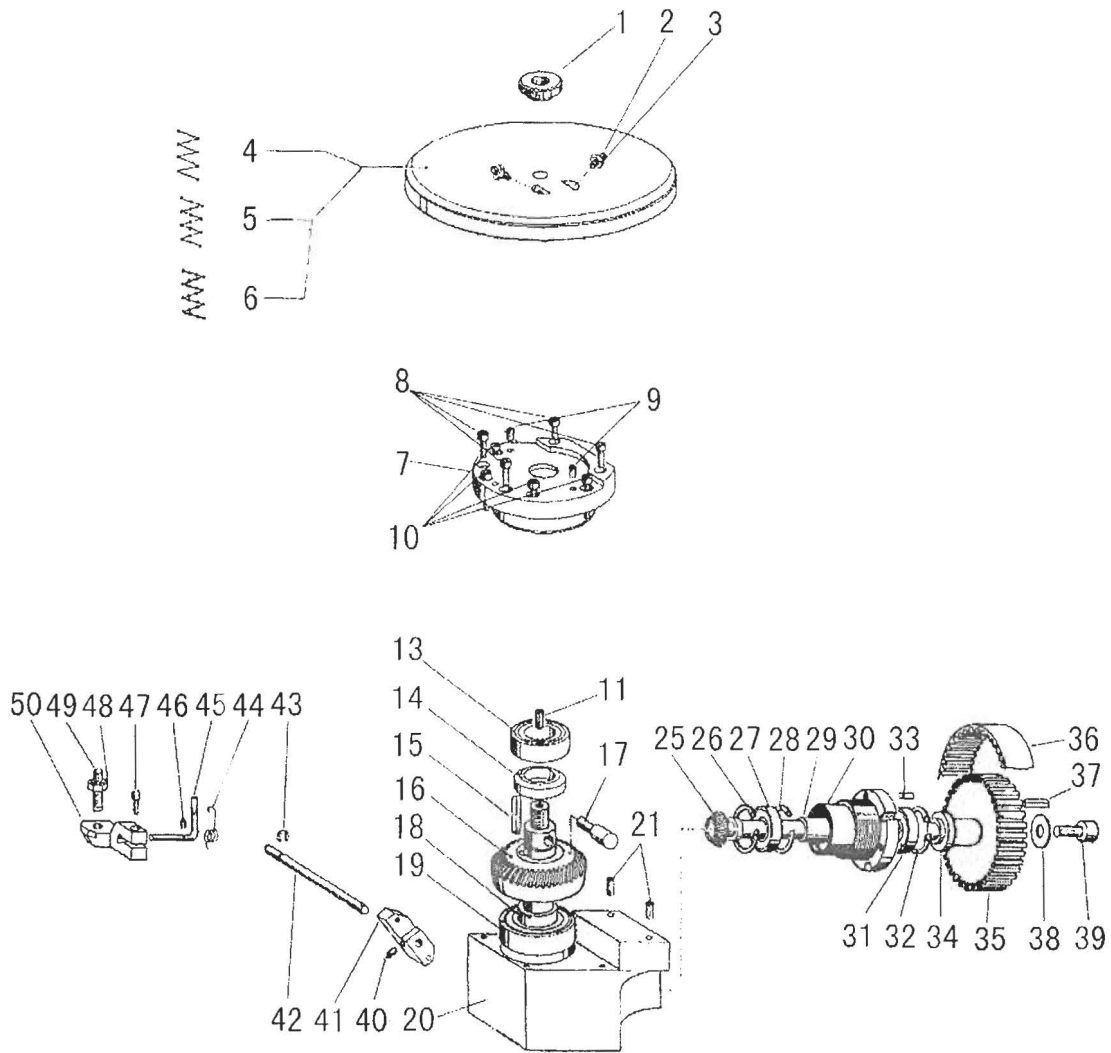

## D. CAM MACHANISM

Fig. No.	Part No.	Description	Pcs.	Remarks
D01	HM804E8001	Nut	1	
D02	H415060250	Screw	2	
D03	H003001060	Nut	2	
D02	H415060250	Screw	2	
D03	H003001060	Nut	2	
D02	H415060250	Screw	2	
D03	H003001060	Nut	2	
D04	HM808E8001	Cam	1	
D05	HM809E8001	Cam	1	
D06	HM810E8001	Cam	1	
D07	HM814E8001	Cover	1	
D08	H415060160	Screw	4	
D09	H431060060	Screw	3	
D10	H415060160	Screw	4	
D11	H431080100	Screw	1	
D12				
D13	IM818E8001	Bearing	1	φ 25 × φ 47 × 12 (NTN6005ZZ)
D14	IM819E8001	Washer	1	
D15	HE00	Pin	1	
D16	IM821E8001	Gear (big)	1	
D17	IM822E8001	Shaft	1	
D18	IM823E8001	Shaft	1	
D19	IM824E8001	Bearing	1	φ 30 × φ 62 × 16 (NTN6206ZZ)
D20	HM825E8001	Setting platform for cam	1	
D21	H431060060	Screw	2	
D25	HM829E8001	Gear (small)	1	
D26	H007007320	Retaining ring	1	
D27	IM830E8001	Bearing	2	φ 15 × φ 32 × 9 (NTN6002ZZ)
D28	H007007320	Retaining ring	1	
D29	IM831E8001	Bushing	1	
D30	IM832E8001	Adjusting bushing	1	
D31	IM830E8001	Bearing	1	
D32	H007007320	Retaining ring	1	
D33	H431060100	Screw	3	
D34	IM836E8001	Washer	1	
D35	IM838E8001	Belt pulley (big)	1	
D36	IM839E8001	Belt	1	
D37		Bond	1	
D38	H7329C8001	Screw	1	
D39	H415060120	Screw	1	
D40	H424040060	Screw	1	
D41	IM843E8001	Controlling block	1	
D42	IM844E8001	Shaft	1	

## D. CAM MACHANISM

Fig. No.	Part No.	Description	Pcs.	Remarks
D43	H007013060	Retaining ring	1	
D44	HM846E8001	Spring	1	
D45	HM847E8001	Shaft	1	
D46				
D47	H415040140	Screw	1	
D48	H003002080	Nut	1	
D49	HM848E8001	Screw	1	
D50	HM849E8001	Setting bracket	1	

# E. FEED MECHANISM

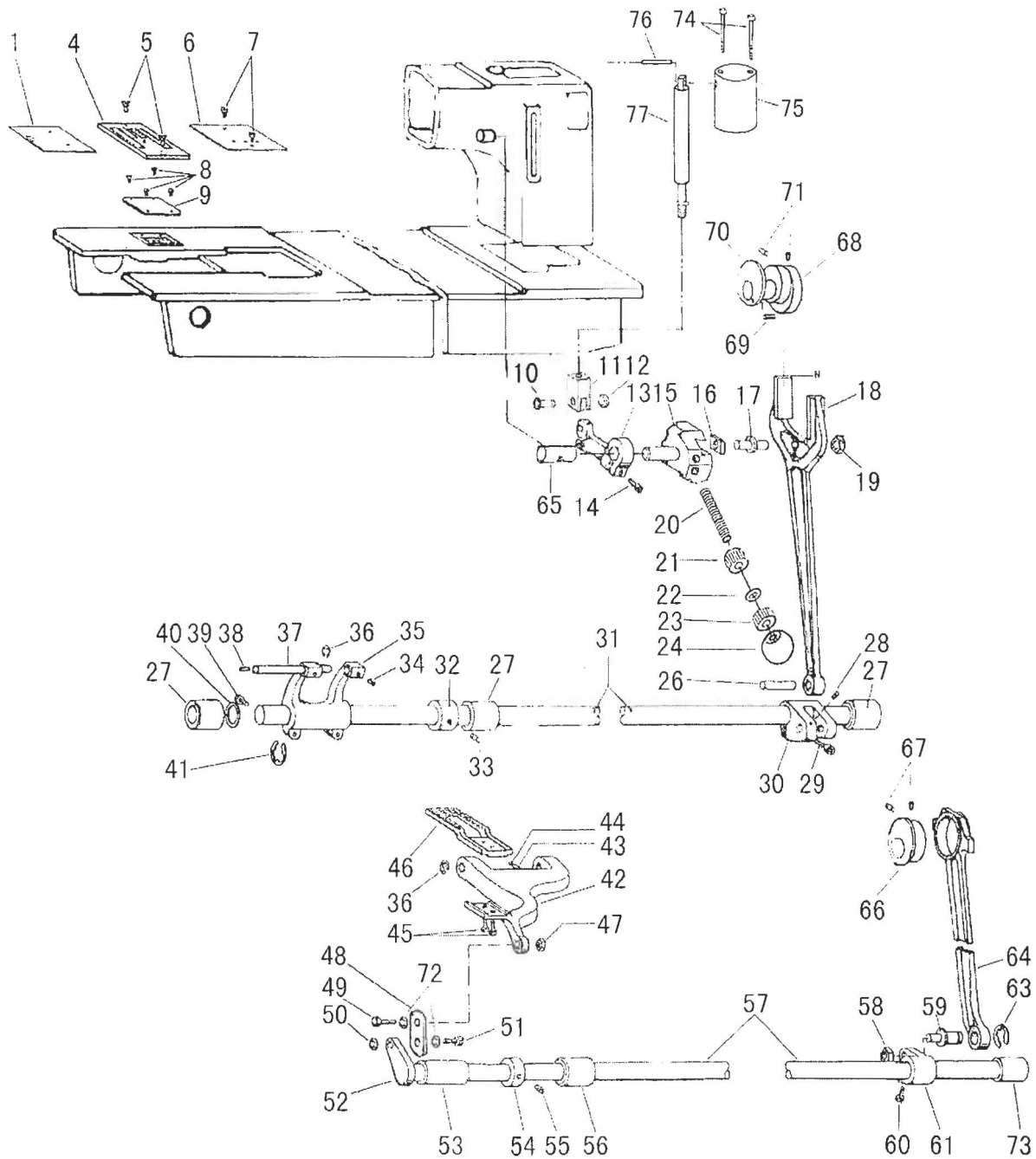

## E. FEED MECHANISM

Fig. No.	Part No.	Description	Pcs.	Remarks
E01	HM805F8001	Left slide plate	1	
E04	HM807F8001	Needle plate	1	
E05	H7326E8001	Screw	2	
E06	HM811F8001	Right slide plate	1	
E07	H7326E8001	Screw	2	
E08	H415060100	Screw	4	
E09	HM812F8001	Cover	1	
E10	HM818F8001	Pin	1	
E11	HM819F8001	Joint	1	
E12	H007013035	Retaining ring	1	
E13	HM820F8001	Crank	1	
E14	H415050160	Screw	1	
E15	HM821F7101	Reverse stitching arm complete	1	
E16	HM824F8001	Slide block	1	
E17	HM826F8001	Screw	1	
E18	HM827F8001	Feed forked connection	1	
E19	H003008080	Nut	1	
E20	HM828F8001	Screw	1	
E21	HH572C8001	Nut		
E22	H00500108001	Washer		
E23	HH574C8001	Nut	1	
E24	HE72711832	Nut	1	
E26	HM834F8001	Pin	1	
E27	HM835F8001	Bushing	3	
E28	H415040060	Screw	1	
E29	H415060160	Screw	1	
E30	HM837F8001	Crank	1	
E31	HM838F8001	Shaft	1	
E32	HE033H8001	Collor	1	
E33	HE034H8001	Screw	2	SM17/64" (6.75) × 24
E34	H431050050	Screw	2	
E35	HM843F8001	Crank	1	
E36	H007013060	Retaining ring	1	
E37	HM844F8001	Pin	1	
E38	HM845F8001	Oil wick	1	
E39	H415060120	Screw	2	
E40	HM846F8001	Washer	1	
E41	H007009130	Retaining ring	1	
E42	HM848F8001	Feed bar	1	
E43	HM849F8001	Tube	1	
E44	HM850F8001	Oil wick	1	
E45	H415050100	Screw	2	
E46	HM851F8001	Feed dog	1	

## E. FEED MECHANISM

Fig. No.	Part No.	Description	Pcs.	Remarks
E47	H003002060	Nut	1	
E48	HM854F7101	Link complete	1	
E49	H415060180	Screw	1	
E50	H003002060	Nut	1	
E51	H415060180	Screw	1	
E52	HM856F8001	Feed connecting arm	1	
E53	HM857F8001	Bushing	1	
E54	HE033H8001	Collor	1	
E55	HE034H8001	Screw	2	SM17/64" (6.75) × 24
E56	HM860F8001	Bushing	1	
E57	HM861F8001	Shaft	1	
E58	H003001080	Nut	1	
E59	HM864F8001	Screw	1	
E60	H415060120	Screw	1	
E62	HM868F8001	Feed connecting arm	1	
E63	H007013090	Retaining ring	1	
E64	HM870F8001	Feed link	1	
E65	HM867F8001	Bushing	1	
E66	HM873F8001	Cam	1	
E67	H431060100	Screw	1	
E68	HM876F8001	Cam	1	
E69	H605030080	Pin	1	
E70	HM878F8001	Baffle	1	
E71	H431060060	Screw	2	
E72	HE00002060	Bearing	2	
E73	HM879F8001	Bushing	1	

F. LOWER SHAF MACHANISM

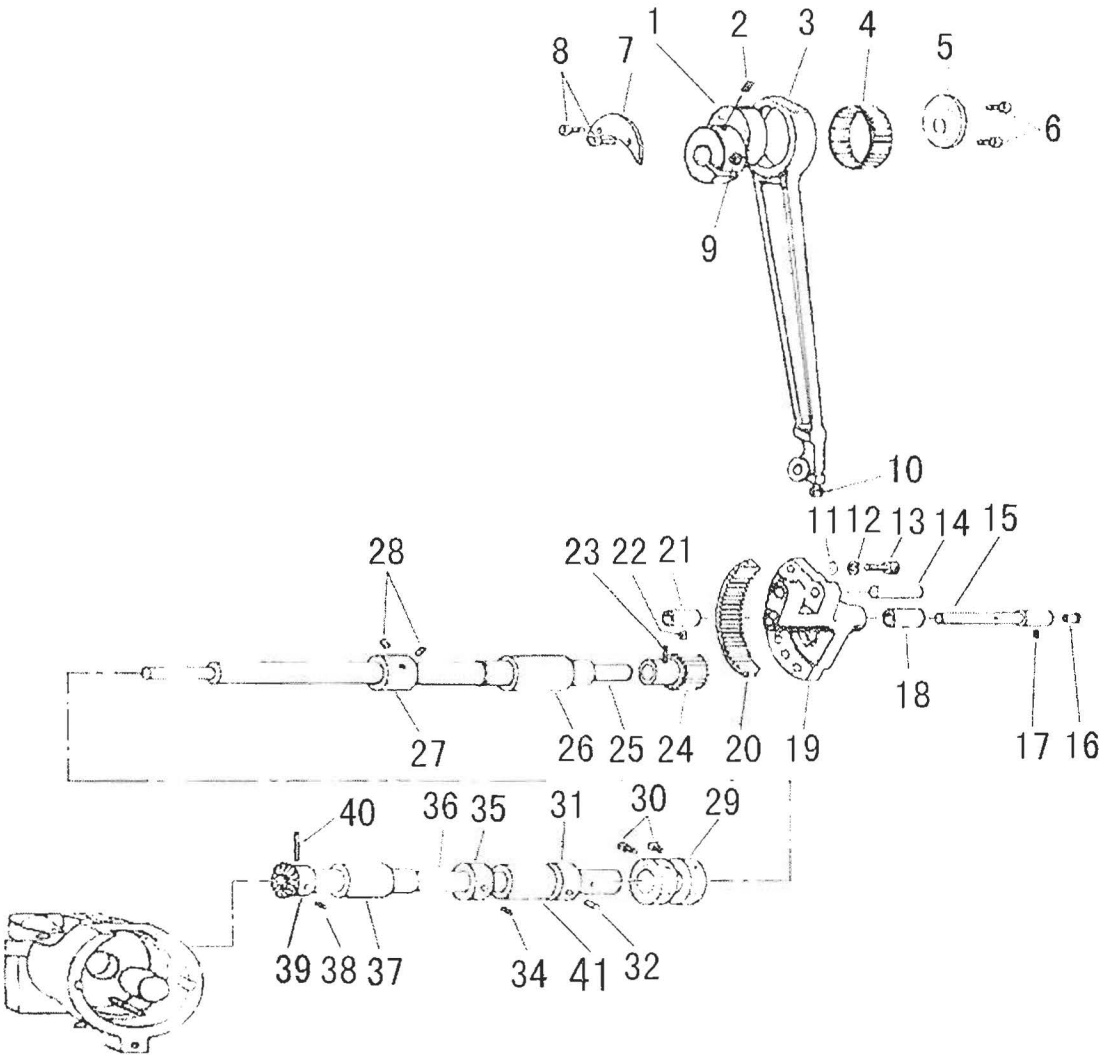



## F. LOWER SHAFT MACHANISM

Fig. No.	Part No.	Description	Pcs.	Remarks
F01	HM807G8001	Cam	1	φ 52 × φ 45 × 12 HK4512 (NSK)
F02	H431060080	Screw	2	
F03	HM808G8001	Link	1	
F04	HM809G8001	Bearing	1	
F05	HM810G8001	Baffle	1	
F06	H415040060	Screw	2	
F07	HM812G8001	Baffle	1	
F08	H415040060	Screw	2	
F09	H415080250	Screw	1	
F10	H415050160	Screw	1	
F11	H415050	Screw	3	
F12	H005010060	Washer	3	
F13	H415050160	Screw	3	
F14	HM814G8001	Pin	1	
F15	HM815G7101	Shaft complete	1	
F16	HE11500080	Oil cup	1	
F17	H415050160	Screw	1	
F18	HM819G8001	Bushing	1	
F19	HM820G8001		1	
F20	HM821G8001	Gear	1	
F21	HM822G8001	Bushing	1	
F22	H431050050	Screw	1	
F23	H602040220	Pin	1	
F24	HM826G8001	Gear	1	
F25	HM827G8001	Shaft	1	
F26	HM828G8001	Bushing	1	
F27	HA108G0661	Collor	1	
F28	HA105D0662	Screw	2	
F29	HM831G8001	Coupling crow	1	
F30	H415060160	Screw	2	
F31	HM834G8001	Collor	1	
F32	H431050050	Screw	2	
F33	HM835G8001	Bushing	1	
F34	H431050050	Screw	2	
F35	HM834G8001	Collor	1	
F36	HM837G8001	Shaft	1	
F37	HM835G8001	Bushing	1	
F38	H431060060	Screw	1	
F39	HM838G8001	Gear	1	
F40	H602040240	Pin	1	
F41	HM839G8001	Bushing	1	

# G. SHUTTLE HOOK MECHANISM

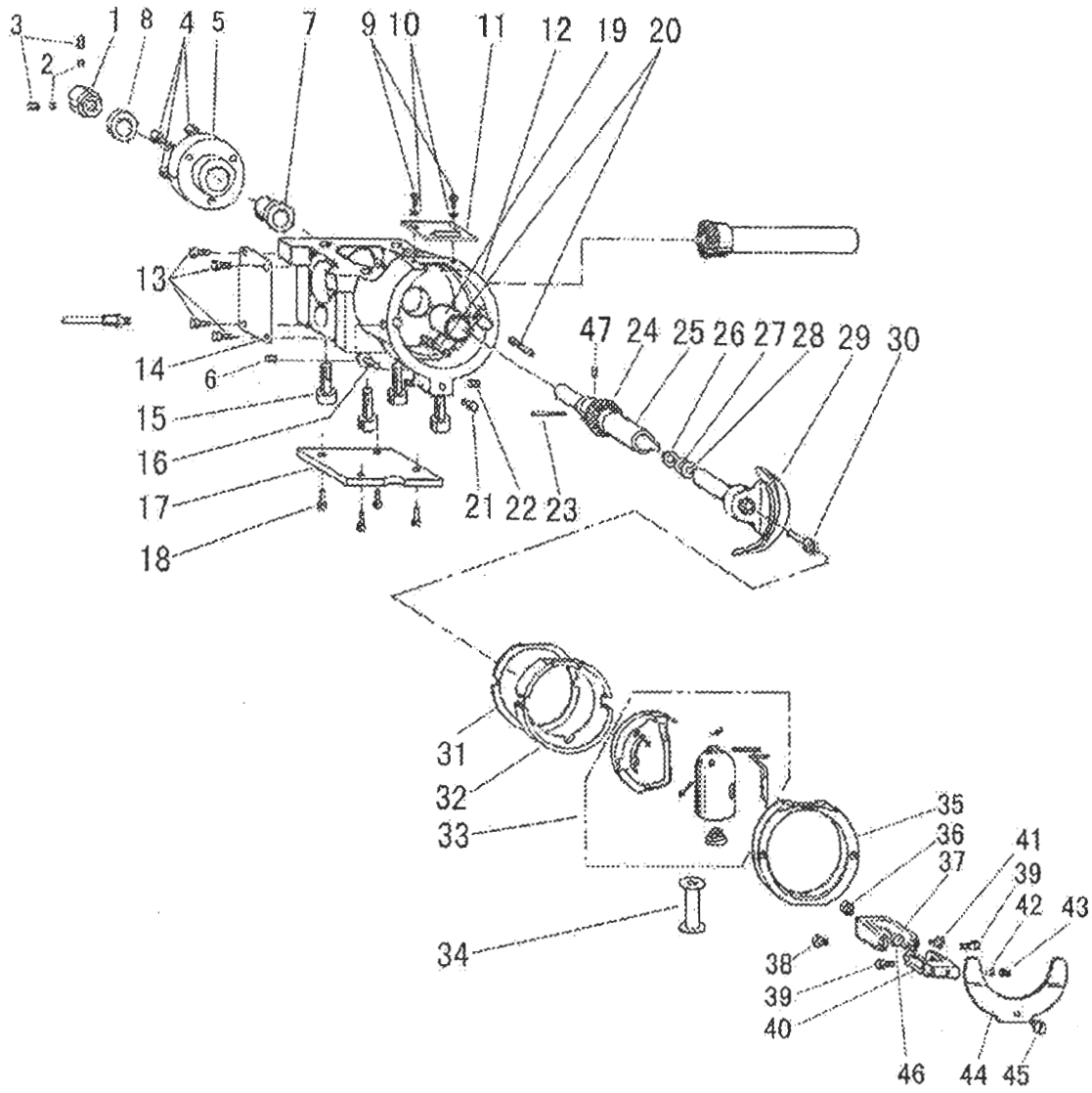

## G. SHUTTLE HOOK MECHANISM

Fig. No.	Part No.	Description	Pcs.	Remarks
G01	HM806H8001	Nut	1	
G02	HM807H8001	Block	2	
G03	H431040040	Screw	2	
G04	H415040100	Screw	3	
G05	HM809H8001	Bushing	1	
G06	H431050050	Screw	1	
G07	HM810H8001	Bushing	1	
G08	HM811H8001	Washer	1	
G09	H401030060	Screw	2	
G10	H005001030	Washer	2	
G11	HM812H8001	Needle-protecting plate	1	
G12	HM813H8001	Hook base	1	
G13	H415040100	Screw	4	
G14	HM814H8001	Cover	1	
G15		Screw	4	
G16	HM841H8001	Pin	1	
G17	HM815H8001	Cover	1	
G18	H415040100	Screw	4	
G19	HM816H8001	Bushing	1	
G20	HM817H8001	Pin	2	
G21	HM842H8001	Screw	1	
G22	H431050050	Screw	2	
G23	H602040240	Pin	1	
G24	HM819H8001	Gear	1	
G25	HM820H8001	Hook shaft	1	
G26	H7362G8001	Washer	1	
G27	H7362G8001	Washer	2	
G28	H2405H1044	Washer	3	
G29	HM824H8001	Shuttle driver	1	
G30	H415060550	Screw	1	
G31	HM825H8001	Spacer	2	0.2
G32	HM828H8001	Shuttle race body	1	
G33	H7240D7101	Hook complete	1	
G34	H7228D8001	Bobbin	1	
G35	HM830H8001	Shuttle race back ring	1	
G36	H003002040	Nut	1	
G37	HM833H8001	Spanner	1	
G38	H2409G0683	Screw	1	
G39	HM835H8001	Screw	2	
G40	HM836H8001	Setting bracket	1	
G41	H2409G0683	Screw	1	
G42	HM837H8001	Block	1	
G43	H431050050	Screw	1	

### G. SHUTTLE HOOK MECHANISM

Fig. No.	Part No.	Description	Pcs.	Remarks
G44	HM838H8001	Spring	1	
G45	HM839H8001	Screw	1	
G46	HM840H8001	Screw	1	
G47	H431060060	Screw	1	

H. THREAD MECHANISM AND BOBBIN WINDER MECHANISM

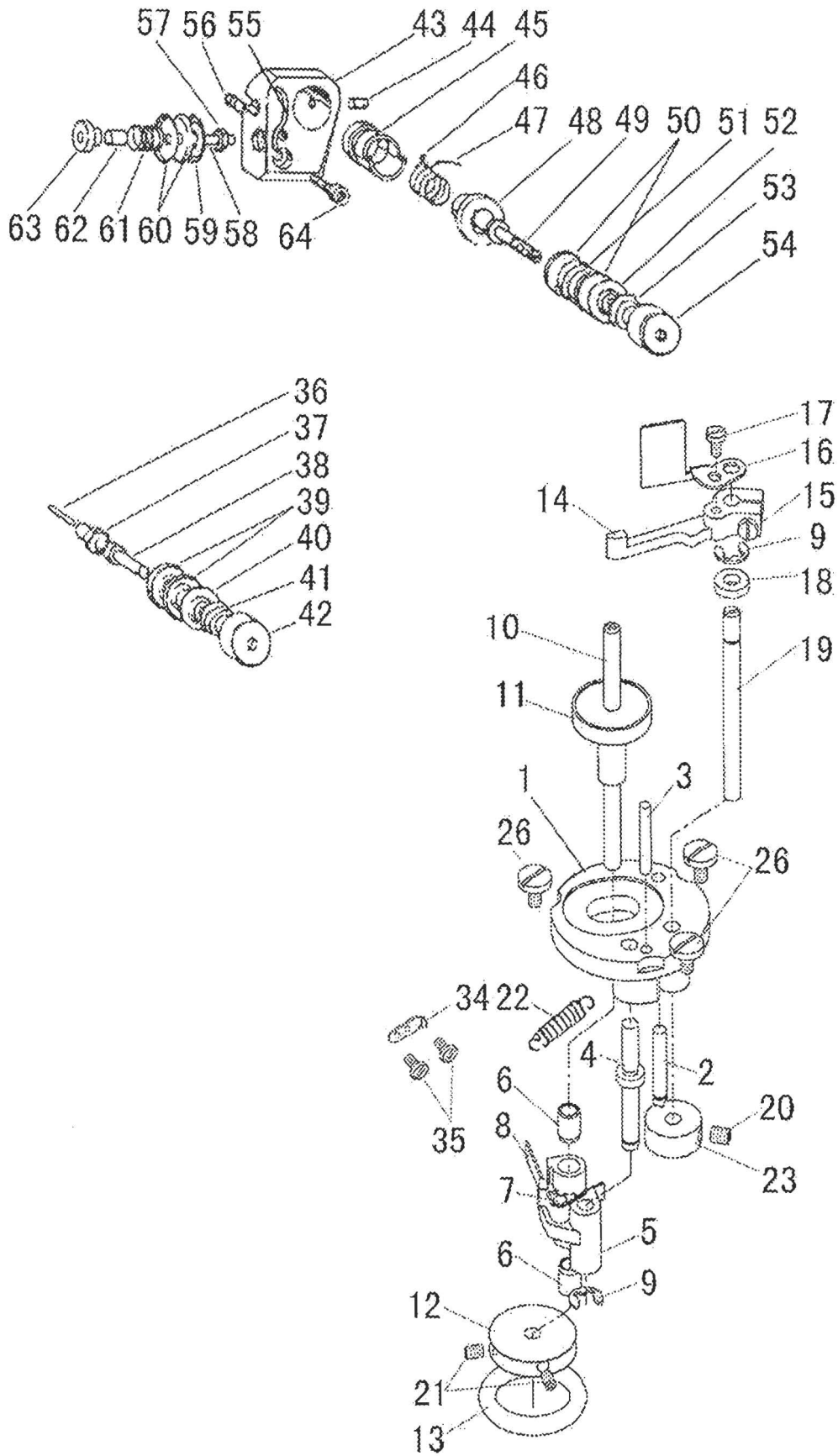

## H. THREAD MECHANISM AND BOBBIN WINDER MECHANISM

Fig. No.	Part No.	Description	Pcs.	Remarks
H01	H6706N8001	Platform	1	
H02	H6707N8001	Pin	1	
H03	H6708N8001	Pin	1	
H04	H7210J8001	Shaft	1	
H05	H7213J8001	Crank	1	
H06	H6713N8001	Bushing	2	
H07	H6714N8001	Pin	1	
H08	H6715N8001	Spring	1	
H09	H007013050	Retaining ring	2	GB/T896 5
H10	H7205J8001	Shaft	1	
H11	H6717N8001	Bobbin case	1	
H12	H7214J8001	Wheel	1	
H13	H6658B8001	Rubber ring	1	
H14	H6720N8001	Spanner	1	
H15	HA100H2150	Screw	1	SM9/64(40) × 11
H16	H7206J8001	Screw	1	
H17	H3200B2100	Screw	1	
H18	H6722N8001	Washing	1	
H19	H6723N8001	Shaft	1	
H20	H6731N8001	Screw	1	M5 × 6
H21	H431030040	Screw	2	
H22	H6724N8001	Spring	1	
H23	H6725N8001	Cam	1	
H26	H3107G0662	Screw	3	SM11/64(40) × 8
H34	H6756B8001	Felt	1	
H35	HA500C2070	Screw	2	SM9/64(40) × 5
H36	HM805I8001	Pin	1	
H37	H003008080	Nut	1	
H38	HM806I8001	Screw	1	
H39	HA310B0705	Tension discs	2	
H40	HA310B0702	Tension release plate	1	
H41	H2206B0671	Spring	1	
H42	HA310B0701	Tension adjusting nut complete	1	
H43	HM812I8001	Setting block	1	
H44	H431050050	Screw	1	
H45	HM813I8001	Bushing	1	
H46	HH524H8001	Spring	1	
H47	HM817I8001	Spring	1	
H48	HH526H8001	Adjusting plate	1	
H49	HM819I8001	Screw	1	
H50	HM820I8001	Washer	2	
H51	HM821I8001	Thread guide	1	
H52	HM822I8001	Spring	1	

## H. THREAD MECHANISM AND BOBBIN WINDER MECHANISM

Fig. No.	Part No.	Description	Pcs.	Remarks
H53	HA310B0702	Tension release plate	1	
H54	HA310B0701	Thumb nut	1	
H55	HM824I8001	Thread guide	1	
H56		Pin	1	
H57	H003008050	Nut	1	
H58	HM825I8001	Screw	1	
H59	HM826I8001	Washer	1	
H60	HA310B0705	Tension discs	2	
H61	HM808I8001	Spring	1	
H62	HM827I8001	Bushing	1	
H63	HM828I8001	Nut	1	
H64	H415060160	Screw	1	

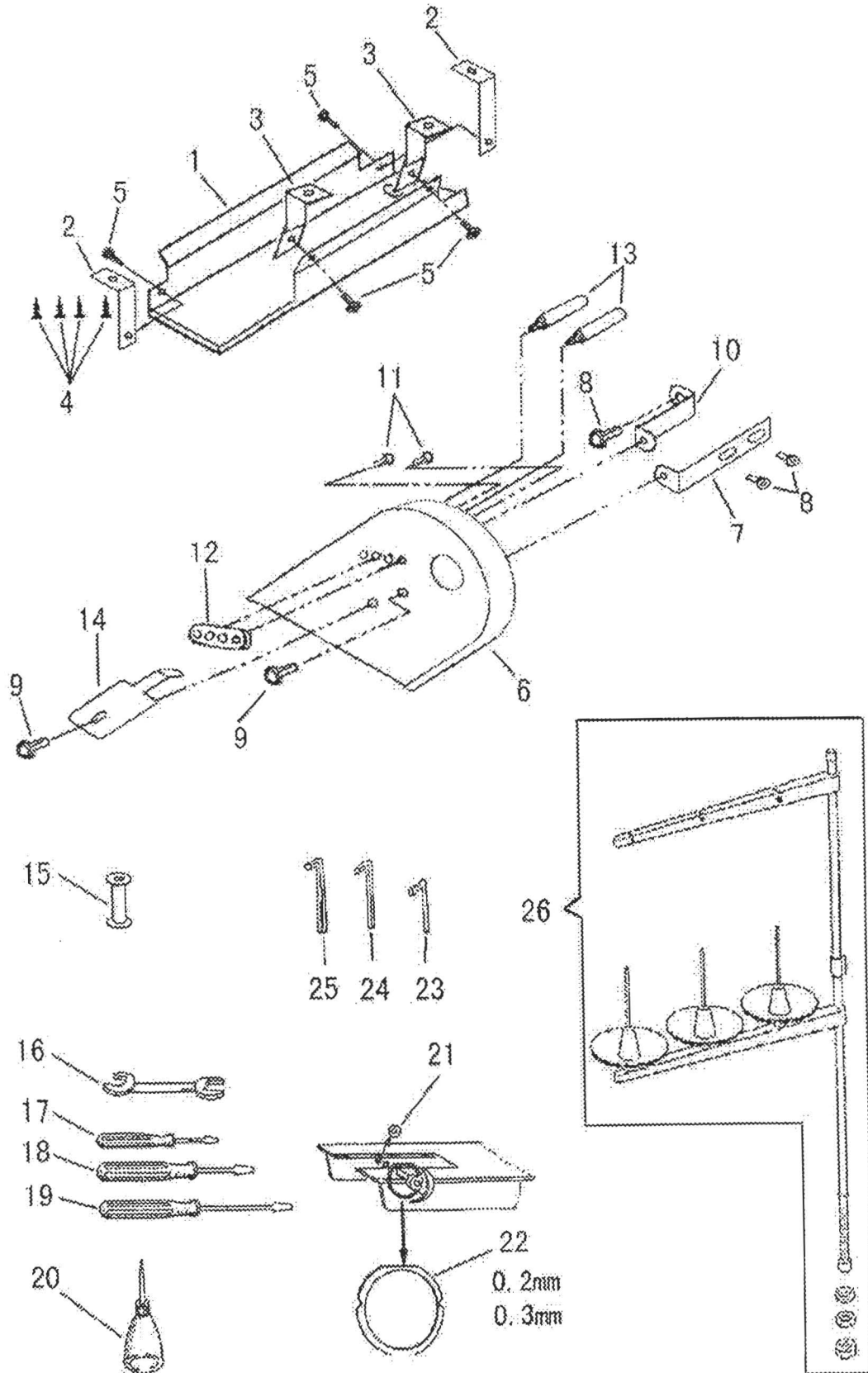



J.

Fig. No.	Part No.	Description	Pcs.	Remarks
J1	HM806K8001	Oil pan	1	
J2	HM807K8001	Block	2	
J3	HM808K8001	Block	2	
J4	H801045200	Screw	4	
J5	H409040050	Screw	4	
J6	HM809K7101	Belt guard	1	
J7	HM811K8001	Block	1	
J8	H415080120	Screw	3	
J9	H415040060	Screw	2	
J10	HM812K8001	Block	1	
J11	H409040050	Screw	2	
J12	HM813K8001		1	
J13	HM814K8001	screw	2	
J14	HF913L8001		1	
J15	H7228D8001	Bobbin	3	
J16	HA300J2220	Double head wrench	1	
J17	HA300J2210	wrench	1	
J18	HA300J2200	wrench	1	
J19	HA300J2070	wrench	1	
J20	HA100J2110	Oiler	1	
J21	H7362G8001	Washer	3	
	H2405H1044	Washer	3	
J22	HM825H8001	Spacer	2	0.2
	HM825H8002	Spacer	2	0.3
J23	HB00001015	Wrench	1	1.5
J24	HB00001030	Wrench	1	3
J25	HB00001025	Wrench	1	2.5
J26	HA200J2030	Thread stand	1	